

The two-body problem in modified gravity

Adrien Kuntz

PhD student in CPT Marseille
Supervisor : Federico Piazza

CENTRA, Lisbon
03/10/2019

Motivation

GR is amazingly tested on small scales :

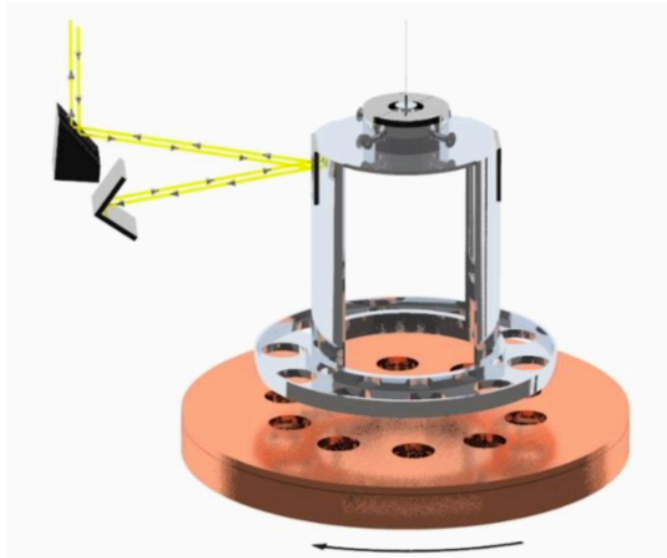

Laboratory experiments (Eotwash) tests of fifth forces and equivalence principle
0.1 mm

Cassini probe test of fifth forces
1 a.u., 150 million km.

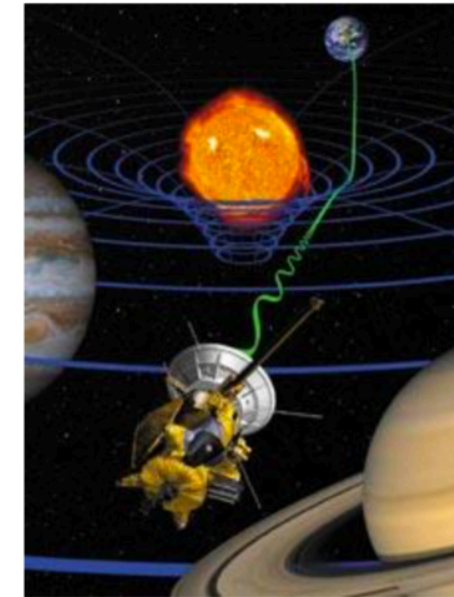

Lunar ranging tests of strong equivalence principle and time variation of Newton's constant, 400 000 km

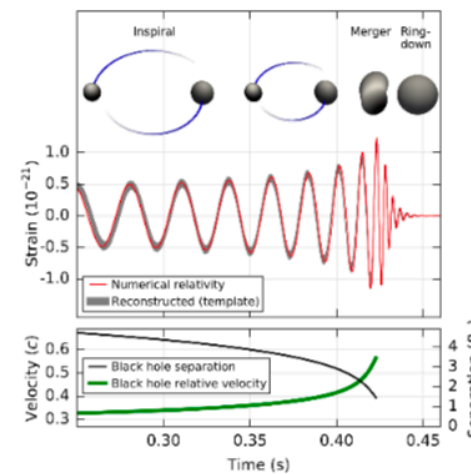

Gravitational wave emissions from black hole and neutron star mergers
50 Mpc

Motivation

But it is still quite mysterious on large scales !

$$S_{\Lambda\text{CDM}} = \frac{1}{16\pi G} \int d^4x \sqrt{-g} (R - 2\Lambda)$$

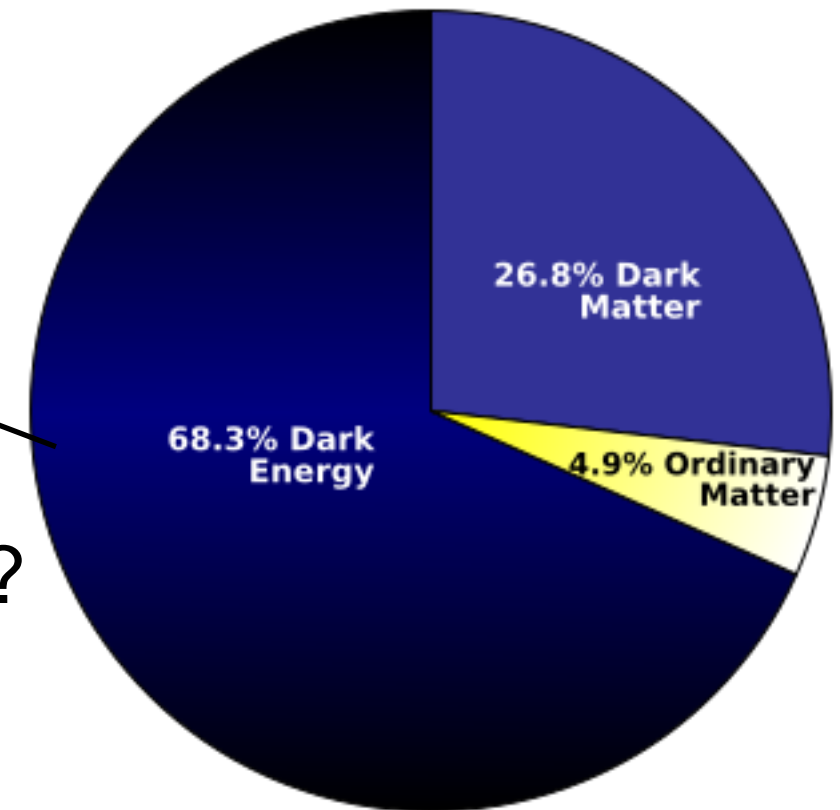

What if Dark Energy was not so simple as Λ ?

$$\Lambda \rightarrow \rho_\phi = \frac{\dot{\phi}^2}{2} + V(\phi)$$

This generically violates small-scale tests ! (via the coupling to matter)

Often a screening mechanism is invoked

Motivation

The two-body problem is an ideal playground for testing modifications of gravity

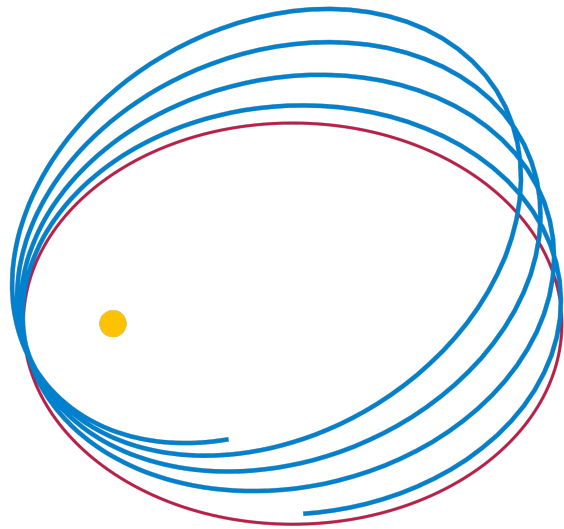

Perihelion precession

Binary pulsars

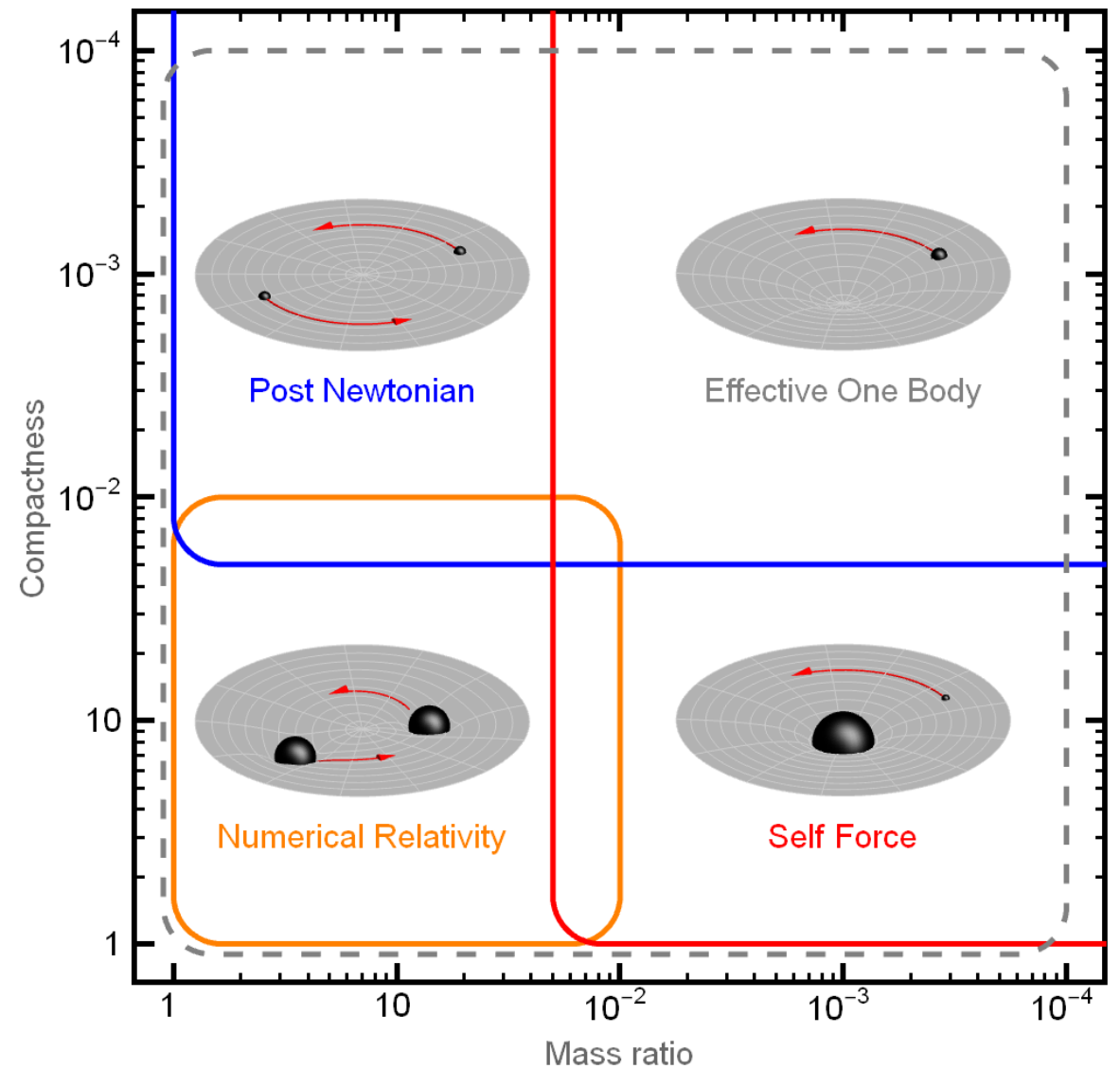
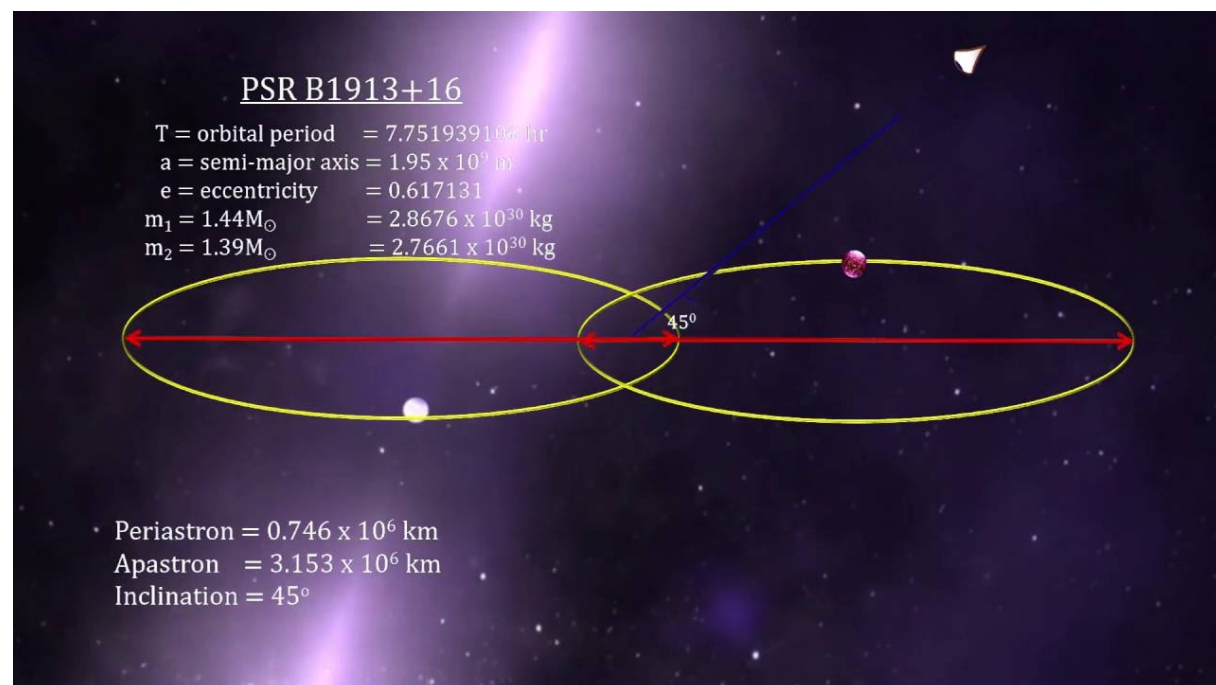

Gravitational waves

Plan

- The two-body problem in GR
- Scalar-Tensor theories and disformal couplings
- Vainshtein screening

The two-body problem in GR

The two-body problem in GR

$$S = \frac{1}{16\pi G} \int d^4x \sqrt{-g} R + S_{\text{pp},1} + S_{\text{pp},2}$$

$$\begin{aligned} S_{\text{pp},A} &= -m_A \int d\tau_A \\ &= -m_A \int dt \sqrt{-g_{\mu\nu} v_A^\mu v_A^\nu} \end{aligned}$$

EFT approach : use field theory tools

Goldberger and Rothstein (2006)
Porto (2006)
+ many others...

$$g_{\mu\nu} = \eta_{\mu\nu} + h_{\mu\nu} \quad \Rightarrow \quad S = S^{(2)} + S_{\text{int}}$$

$\mathcal{O}(v^2) = \mathcal{O}\left(\frac{GM}{r}\right)$

$$S^{(2)} = -\frac{1}{8} \int d^4x \left[-\frac{1}{2} (\partial_\mu h_\alpha^\alpha)^2 + (\partial_\mu h_{\nu\rho})^2 \right]$$

$$S_{\text{int}} = m \int dt \left(\frac{v^2}{2} + \frac{h_{00}}{2} + \dots \right)$$

Expand the propagator :

$$\frac{-i}{k^2 + i\epsilon} = -\frac{i}{\mathbf{k}^2} \left(1 + \frac{k_0^2}{\mathbf{k}^2} + \dots \right)$$

The two-body problem in GR

The two-body dynamics is encoded in the effective action :

$$e^{iS_{\text{eff}}[\mathbf{x}_1(t), \mathbf{x}_2(t)]} = \int \mathcal{D}h_{\mu\nu} e^{iS[\mathbf{x}_1(t), \mathbf{x}_2(t), h_{\mu\nu}]}$$

It has real and imaginary parts :

$$\Re(S_{\text{eff}}) = \int dt L[\mathbf{x}_a, \mathbf{v}_a]$$

$$\Im(S_{\text{eff}}) = \frac{T}{2} \int dE d\Omega \frac{d^2\Gamma}{dE d\Omega}$$

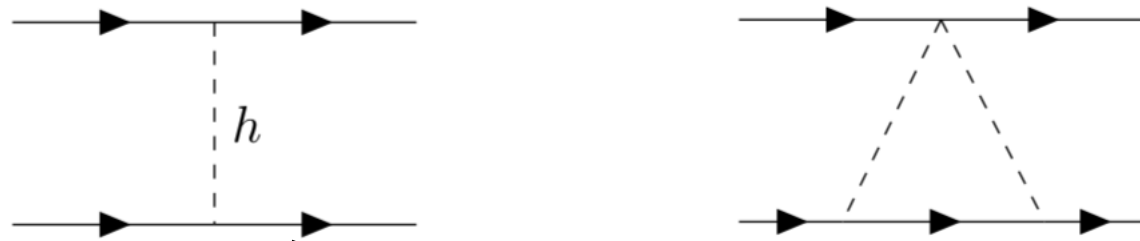

$$L = \frac{1}{2}m_1v_1^2 + \frac{1}{2}m_2v_2^2 + \frac{G_N m_1 m_2}{|\mathbf{x}_1(t) - \mathbf{x}_2(t)|} + L_{1\text{PN}} + \dots$$

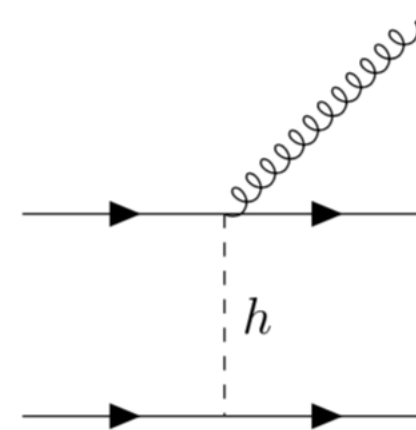

$$P = \frac{G}{5} \left\langle \overset{\dots}{I}_h^{ij} \right\rangle + \dots$$

Scalar-tensor theories and disformal couplings

Modifying GR : scalar-tensor theories

Simplest modification of GR : a new scalar field is present

$$S_\phi = -\frac{1}{2} \int d^4x \sqrt{-g} g^{\mu\nu} \partial_\mu \phi \partial_\nu \phi$$

We generically expect a coupling of ϕ with matter. The most generic compatible with causality and the equivalence principle is : **Bekenstein 92**

$$S_m[\tilde{g}_{\mu\nu}, \psi_i] \quad \text{with} \quad \tilde{g}_{\mu\nu} = A(\phi, X) g_{\mu\nu} + B(\phi, X) \partial_\mu \phi \partial_\nu \phi \quad X = g^{\mu\nu} \partial_\mu \phi \partial_\nu \phi$$

↑ Conformal
 ↙ Disformal

Conformal coupling

Focus first on $\tilde{g}_{\mu\nu} = A(\phi)g_{\mu\nu}$ Dicke, Will, Wagoner, Nordtvedt, Damour, Esposito-Farèse...

$$\Rightarrow S_{\text{int}} = - \int d\tau_A m_A(\phi) = m_A \int d\tau \left(-1 + \alpha_A \frac{\phi}{M_P} + \beta_A \left(\frac{\phi}{M_P} \right)^2 + \dots \right)$$

AK, F. Vernizzi, F. Piazza 19

Conservative

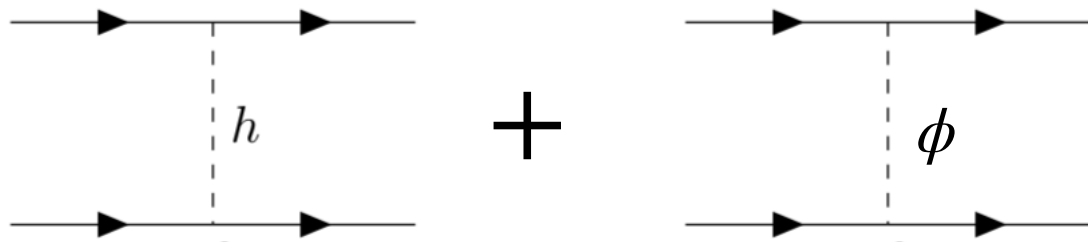

Dissipative

$$\tilde{G}_N = G_N (1 + 2\alpha_1\alpha_2)$$

Conformal coupling

Focus first on $\tilde{g}_{\mu\nu} = A(\phi)g_{\mu\nu}$ **Dicke, Will, Wagoner, Nordtvedt, Damour, Esposito-Farèse...**

$$\Rightarrow S_{\text{int}} = - \int d\tau_A m_A(\phi) = m_A \int d\tau \left(-1 + \alpha_A \frac{\phi}{M_P} + \beta_A \left(\frac{\phi}{M_P} \right)^2 + \dots \right)$$

AK, F. Vernizzi, F. Piazza 19

Conservative

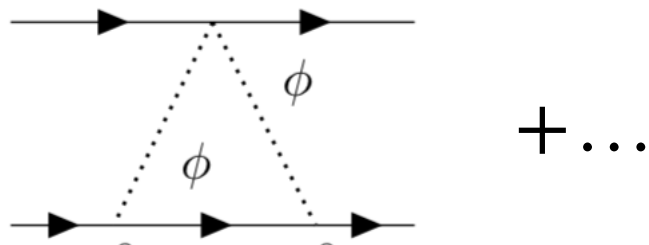

Dissipative

PPN parameters :

$$\gamma_{AB} = 1 - 4 \frac{\alpha_A \alpha_B}{1 + 2\alpha_A \alpha_B}$$

$$\beta_{AB} = 1 - 2 \frac{\alpha_A^2 \alpha_B^2 + f_{AB}}{(1 + 2\alpha_A \alpha_B)^2}$$

Conformal coupling

Focus first on $\tilde{g}_{\mu\nu} = A(\phi)g_{\mu\nu}$ **Dicke, Will, Wagoner, Nordtvedt, Damour, Esposito-Farèse...**

$$\Rightarrow S_{\text{int}} = - \int d\tau_A m_A(\phi) = m_A \int d\tau \left(-1 + \alpha_A \frac{\phi}{M_P} + \beta_A \left(\frac{\phi}{M_P} \right)^2 + \dots \right)$$

AK, F. Vernizzi, F. Piazza 19

Conservative

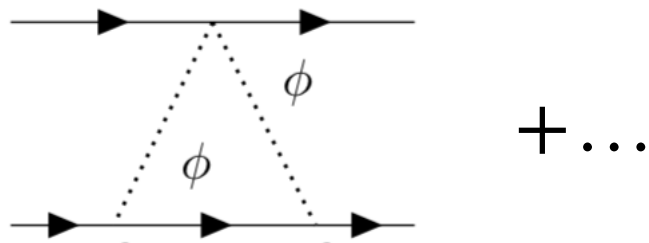

PPN parameters :

$$\gamma_{AB} = 1 - 4 \frac{\alpha_A \alpha_B}{1 + 2\alpha_A \alpha_B}$$

$$\beta_{AB} = 1 - 2 \frac{\alpha_A^2 \alpha_B^2 + f_{AB}}{(1 + 2\alpha_A \alpha_B)^2}$$

Dissipative

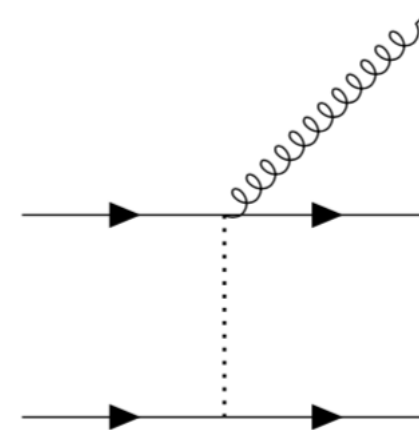

$$P_\phi = 2G_N \left(\left\langle \dot{I}_\phi^2 \right\rangle + \frac{1}{3} \left\langle \ddot{I}_\phi^2 \right\rangle + \frac{1}{30} \left\langle \overset{\dots}{I}_{\phi}^{ij2} \right\rangle + \dots \right)$$

Monopole

Dipole

Quadrupole

Conformal coupling

$$S_{\text{int}} = - \int d\tau_A m_A(\phi) = m_A \int d\tau \left(-1 + \alpha_A \frac{\phi}{M_P} + \beta_A \left(\frac{\phi}{M_P} \right)^2 + \dots \right)$$

Mass renormalization :



$$-m_{\text{bare}} \int dt \rightarrow - (m_{\text{bare}} + E(\Lambda)) \int dt$$

$$\Lambda \sim \frac{1}{r_s}$$



$$E = 0$$

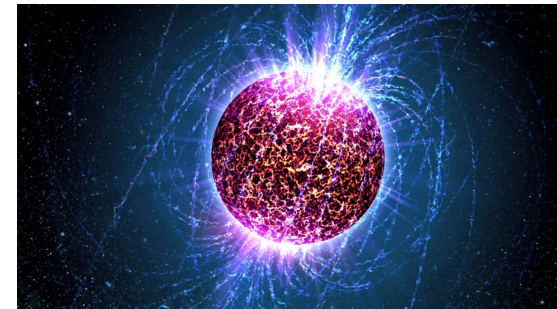

$$E \neq 0$$

Conformal coupling

$$S_{\text{int}} = - \int d\tau_A m_A(\phi) = m_A \int d\tau \left(-1 + \alpha_A \frac{\phi}{M_P} + \beta_A \left(\frac{\phi}{M_P} \right)^2 + \dots \right)$$

Mass renormalization :



$$-m_{\text{bare}} \int dt \rightarrow - (m_{\text{bare}} + E(\Lambda)) \int dt$$

$$\Lambda \sim \frac{1}{r_s}$$



$$E = 0$$

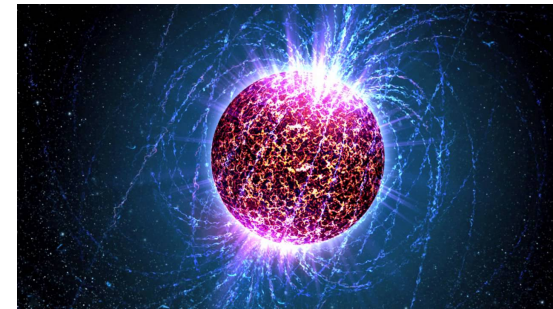

$$E \neq 0$$

Charge renormalization :

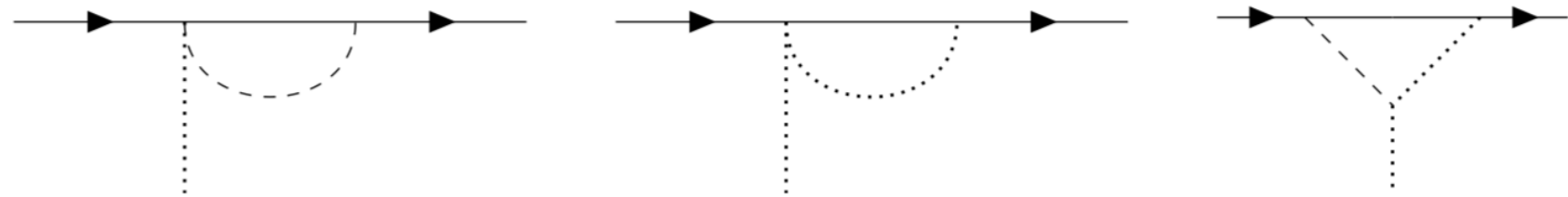

$$\alpha_{\text{bare}} m_{\text{bare}} \int dt \phi \rightarrow \alpha(\Lambda) m(\Lambda) \int dt \phi$$



$$\frac{\tilde{G} m_1 m_2}{r}$$



and $\tilde{G}_N = G_N (1 + 2\alpha_1 \alpha_2)$



$$\frac{\tilde{G}_{12} m_1 m_2}{r}$$



Disformal coupling

$$\tilde{g}_{\mu\nu} = A(\phi)g_{\mu\nu} + B(\phi)\partial_\mu\phi\partial_\nu\phi$$

$$\Rightarrow S_{\text{int}} = m_A \int d\tau \left(-1 + \alpha_A \frac{\phi}{M_P} + \beta_A \left(\frac{\phi}{M_P} \right)^2 + \dots \right) \left(1 + \frac{b_A}{M^2 M_P^2} (\partial_\mu \phi v_A^\mu)^2 + \dots \right)$$

AK, P. Brax, AC Davis 19

Conservative

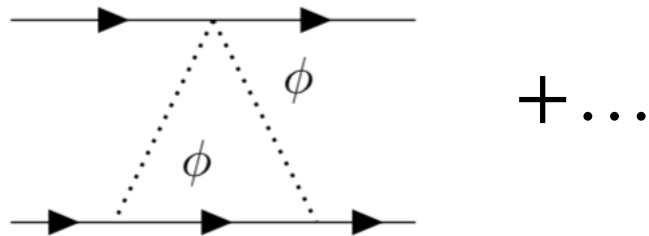

Dissipative

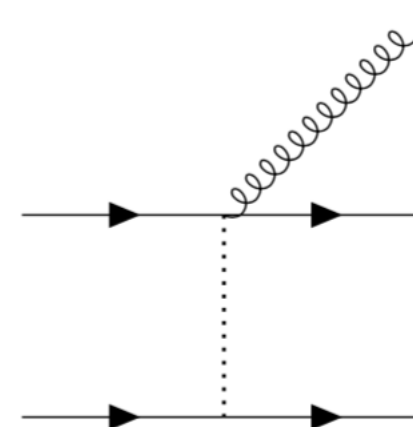

$$L_{\text{dis}} = 4\alpha^2 b \frac{G^2 m_1 m_2 (m_1 + m_2)}{M^2} \left(\frac{d}{dt} \frac{1}{r} \right)^2$$

Monopole

$$I_{\text{dis}} = 8\alpha b \frac{G m_1 m_2}{M^2} \frac{d^2}{dt^2} \frac{1}{r}$$

$$r = |\mathbf{x}_1(t) - \mathbf{x}_2(t)|$$

Disformal coupling

Circular trajectory

$$L_{\text{dis}} = 4\alpha^2 b \frac{G^2 m_1 m_2 (m_1 + m_2)}{M^2} \left(\frac{d}{dt} \frac{1}{r} \right)^2$$

$$I_{\text{dis}} = 8ab \frac{G m_1 m_2}{M^2} \frac{d^2}{dt^2} \frac{1}{r}$$

For circular orbits : $\dot{r} = 0!$

No contribution of the disformal coupling. This is intuitive because :

$$\int d\tau (\partial_\mu \phi v_A^\mu)^2 = \int d\tau \left(\frac{d\phi}{d\tau} \right)^2$$

In this case we showed that only radiation reaction effects contribute

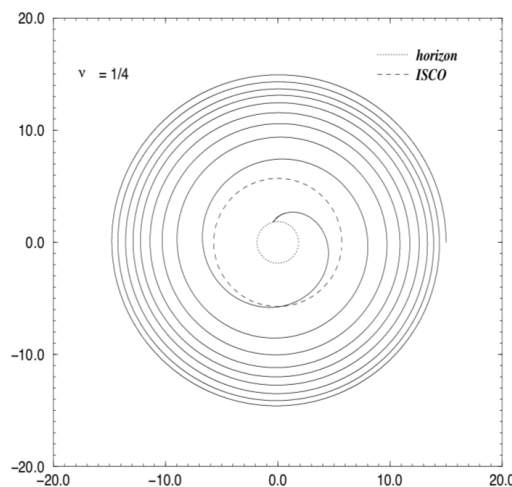

$$\Rightarrow L_{\text{dis}} = \mathcal{O}(v^{14}), \quad I_{\text{dis}} = \mathcal{O}(v^{12})$$

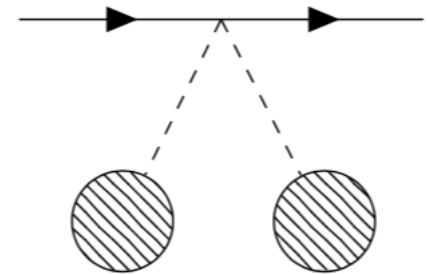

Disformal coupling

Elliptic trajectory

Monopole $I_{\text{dis}} = 8ab \frac{Gm_1m_2}{M^2} \frac{d^2}{dt^2} \frac{1}{r}$

$\Rightarrow P_{\phi}^{\text{mono}} \simeq \frac{64}{9G} \alpha^2 (GM_c \omega)^{10/3} (f_2(e) - 12yf_3(e) + 36y^2 f_4(e))$

$$f_2(e) = \frac{e^2}{(1-e^2)^{7/2}} \left(1 + \frac{1}{4}e^2\right)$$

$$f_3(e) = \frac{e^2}{(1-e^2)^{13/2}} \left(1 + \frac{37}{4}e^2 + \frac{59}{8}e^4 + \frac{27}{64}e^6\right)$$

$$f_4(e) = \frac{e^2}{(1-e^2)^{19/2}} \left(1 + \frac{217}{4}e^2 + \frac{1259}{4}e^4 + \frac{11815}{32}e^6 + \frac{11455}{128}e^8 + \frac{1125}{512}e^{10}\right)$$

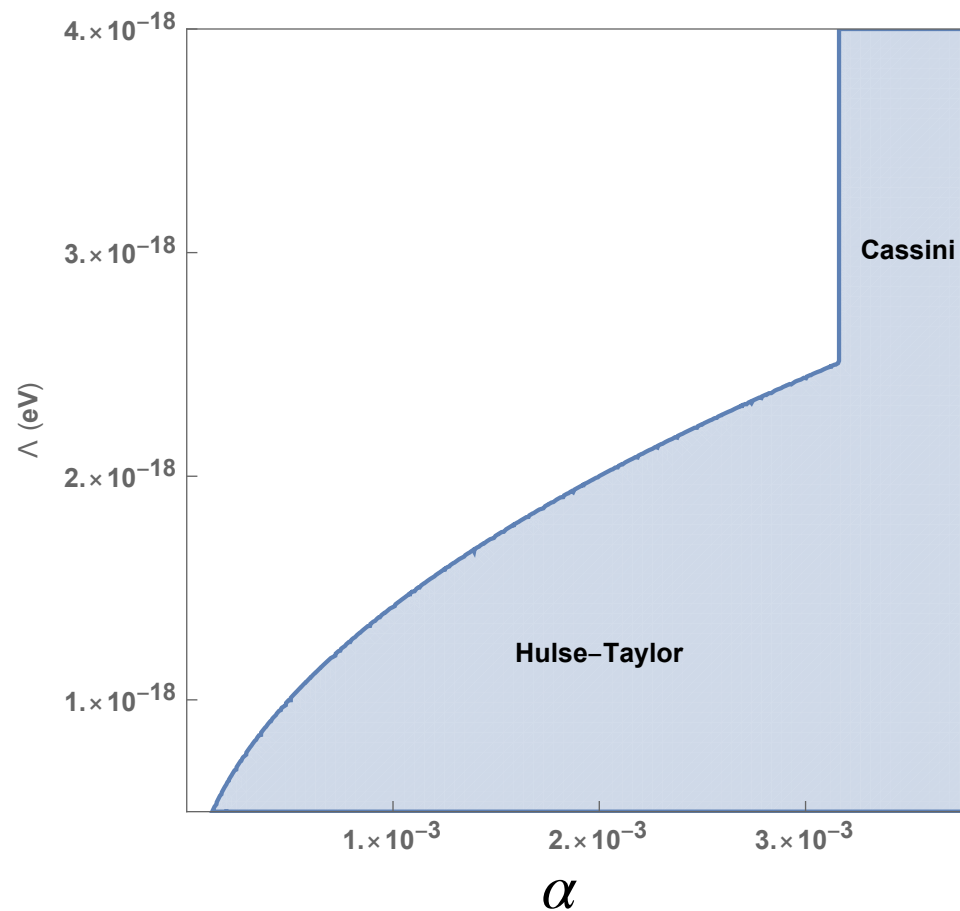

$$y \simeq \left(\frac{\omega}{M}\right)^2$$

$$\omega_{\text{Hulse-Taylor}} \sim 10^{-18} \text{ eV}$$

Vainshtein screening

Motivation

In the theories presented above, GR tests force the couplings to be small

$$\alpha \lesssim 10^{-2}$$

Often a screening mechanism is invoked to have interesting deviations on cosmological scales

$$\phi(r) \simeq 0$$

$$\phi(r) \sim GM/r$$

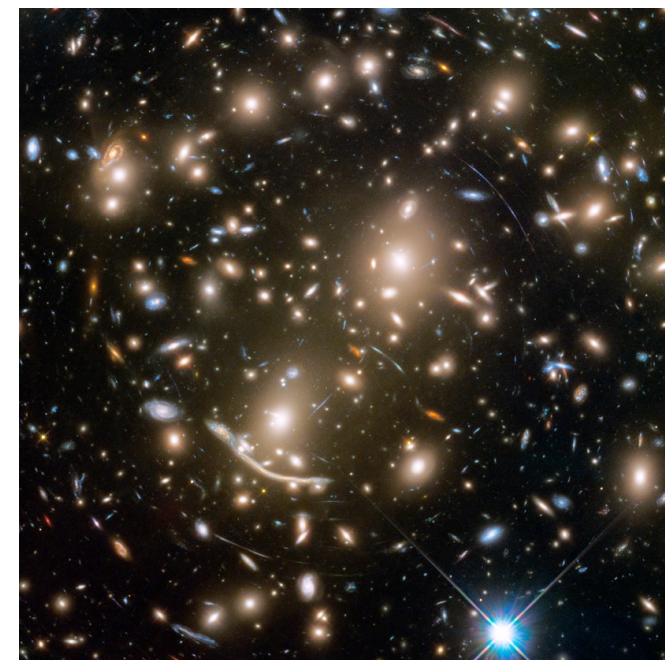
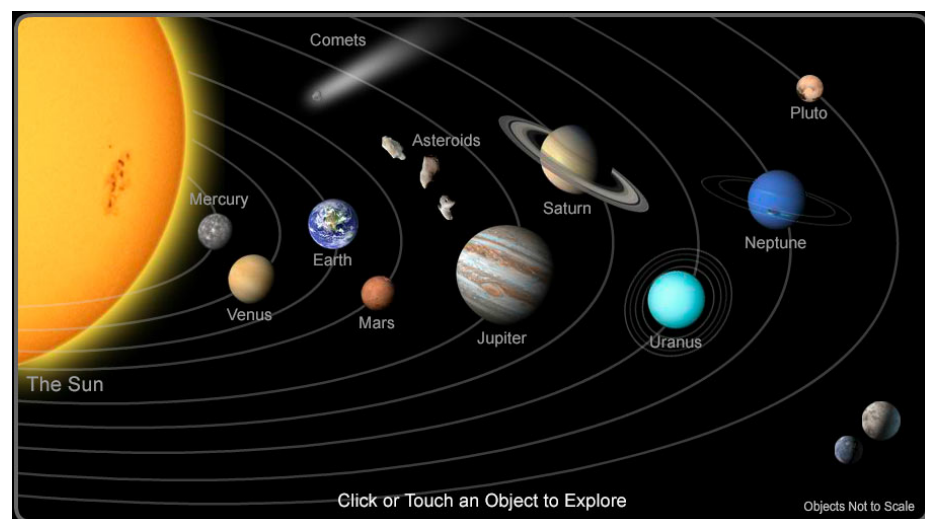

Spherically symmetric screening

Take the simplest Vainshtein screening :
(K-Mouflage)

$$S = \int d^4x \left[-\frac{(\partial\phi)^2}{2} - \frac{1}{4\Lambda^4}(\partial\phi)^4 + \frac{\phi T}{M_P} \right]$$

Barreira et al 2015

Spherically symmetric screening

Take the simplest Vainshtein screening : $\tilde{S} = \int dt d^3x \left[-\frac{1}{2}(\nabla \tilde{\phi})^2 - \frac{1}{4}(\nabla \tilde{\phi})^4 + \tilde{\phi} \tilde{T} \right]$
(K-Mouflage)

Barreira et al 2015

$$\phi' + (\phi')^3 = \frac{M}{r^2}$$

Spherically symmetric screening

Take the simplest Vainshtein screening : $\tilde{S} = \int dt d^3x \left[-\frac{1}{2}(\nabla \tilde{\phi})^2 - \frac{1}{4}(\nabla \tilde{\phi})^4 + \tilde{\phi} \tilde{T} \right]$
(K-Mouflage)

Barreira et al 2015

$$\phi' + (\phi')^3 = \frac{M}{r^2}$$

$$\Rightarrow \phi(r) = -\frac{M}{r} {}_3F_2 \left(\frac{1}{4}, \frac{1}{3}, \frac{2}{3}; \frac{5}{4}, \frac{3}{2}; -\frac{27M^2}{4r^4} \right)$$

$$\phi(r) = 3(Mr)^{1/3} + \dots$$

$$\phi(r) = -\frac{M}{r} + \frac{M^3}{5r^5} + \dots$$

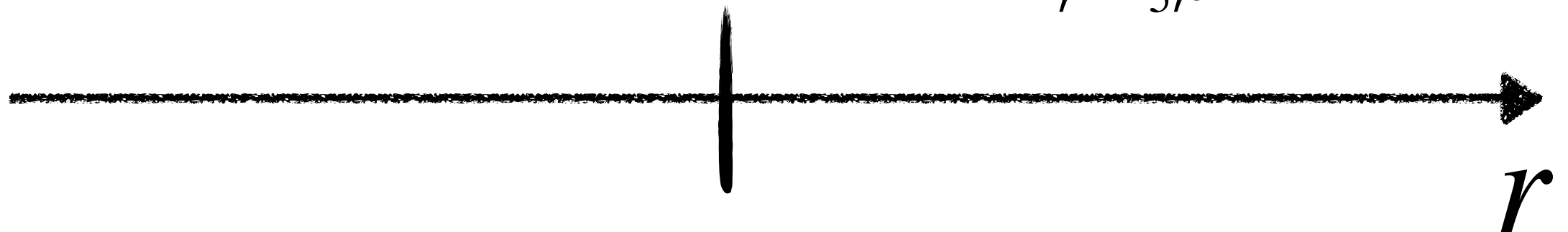
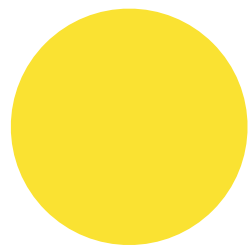

$$r_* = \sqrt{M} (\simeq 1\text{Pc for the Sun})$$

Motivation

Still small-scale tests of GR are very precise !

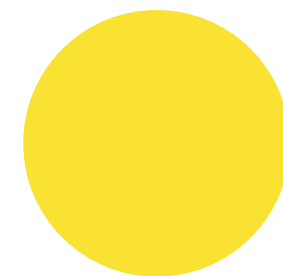
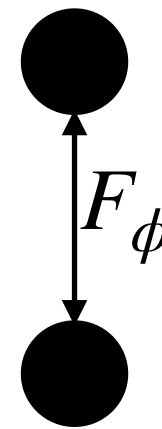
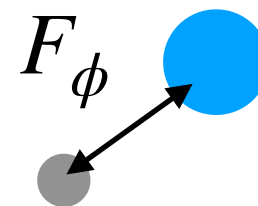
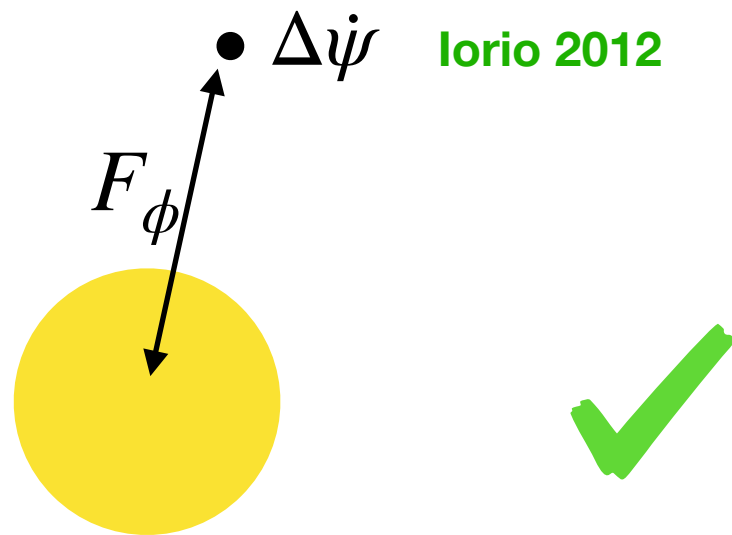

The two-body problem : outside

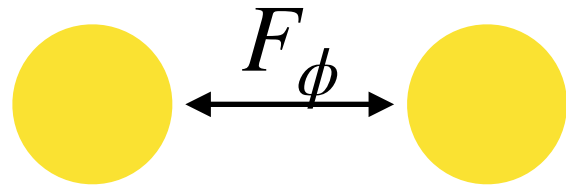

$$\tilde{S} = \int dt d^3x \left[-\frac{1}{2}(\nabla \tilde{\phi})^2 - \frac{1}{4}(\nabla \tilde{\phi})^4 + \tilde{\phi} \tilde{T} \right]$$

$$\tilde{T} = -m_1 \delta^3(\mathbf{x} - \mathbf{x}_1) - m_2 \delta^3(\mathbf{x} - \mathbf{x}_2)$$

The two-body problem : outside

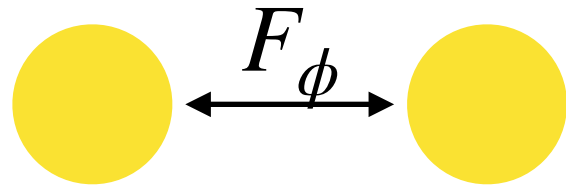

$$\tilde{S} = \int dt d^3x \left[-\frac{1}{2}(\nabla \tilde{\phi})^2 - \frac{1}{4}(\nabla \tilde{\phi})^4 + \tilde{\phi} \tilde{T} \right]$$

$$e^{iS_{\text{cl}}[\mathbf{x}_1, \mathbf{x}_2]} = \int \mathcal{D}[\phi] e^{iS[\mathbf{x}_1, \mathbf{x}_2, \phi]}$$

$$r > r_* \Leftrightarrow (\nabla \phi)^2 > (\nabla \phi)^4$$

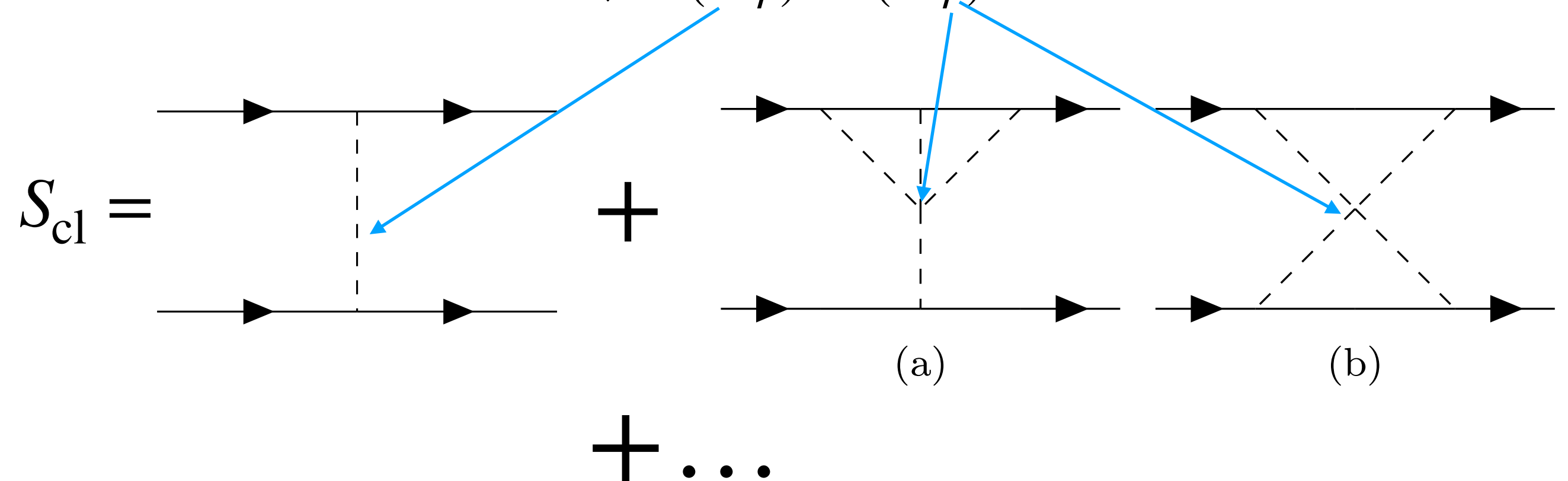

The two-body problem : outside

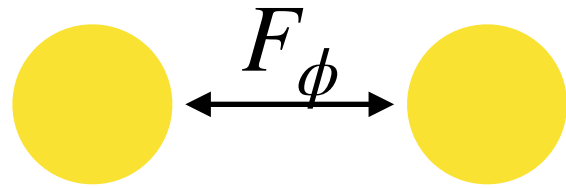

$$\tilde{S} = \int dt d^3x \left[-\frac{1}{2}(\nabla \tilde{\phi})^2 - \frac{1}{4}(\nabla \tilde{\phi})^4 + \tilde{\phi} \tilde{T} \right]$$

$$\int dt E = -S_{\text{cl}} \Rightarrow E = -\frac{m_1 m_2}{r} + \frac{m_1 m_2 (m_1^2 + m_2^2)}{5r^5} + \dots$$

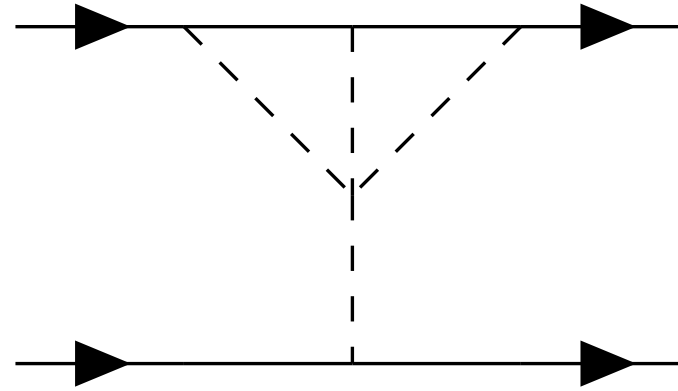
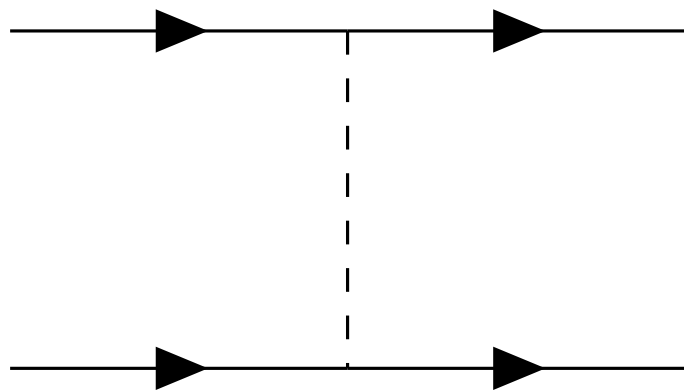

(a)

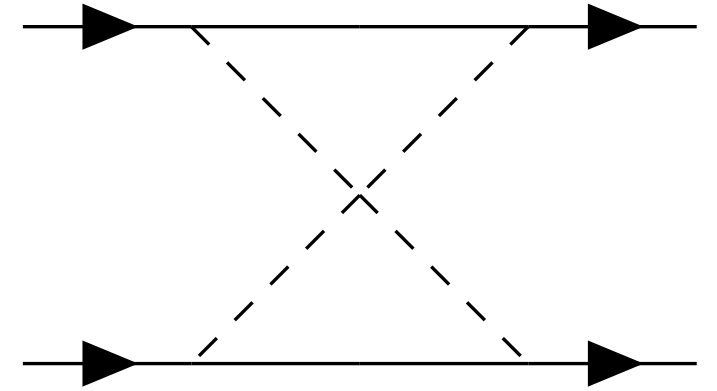

(b)

The two-body problem : outside

$$E = -\frac{m_1 m_2}{r} + \frac{m_1 m_2 (m_1^2 + m_2^2)}{5r^5} + \dots$$

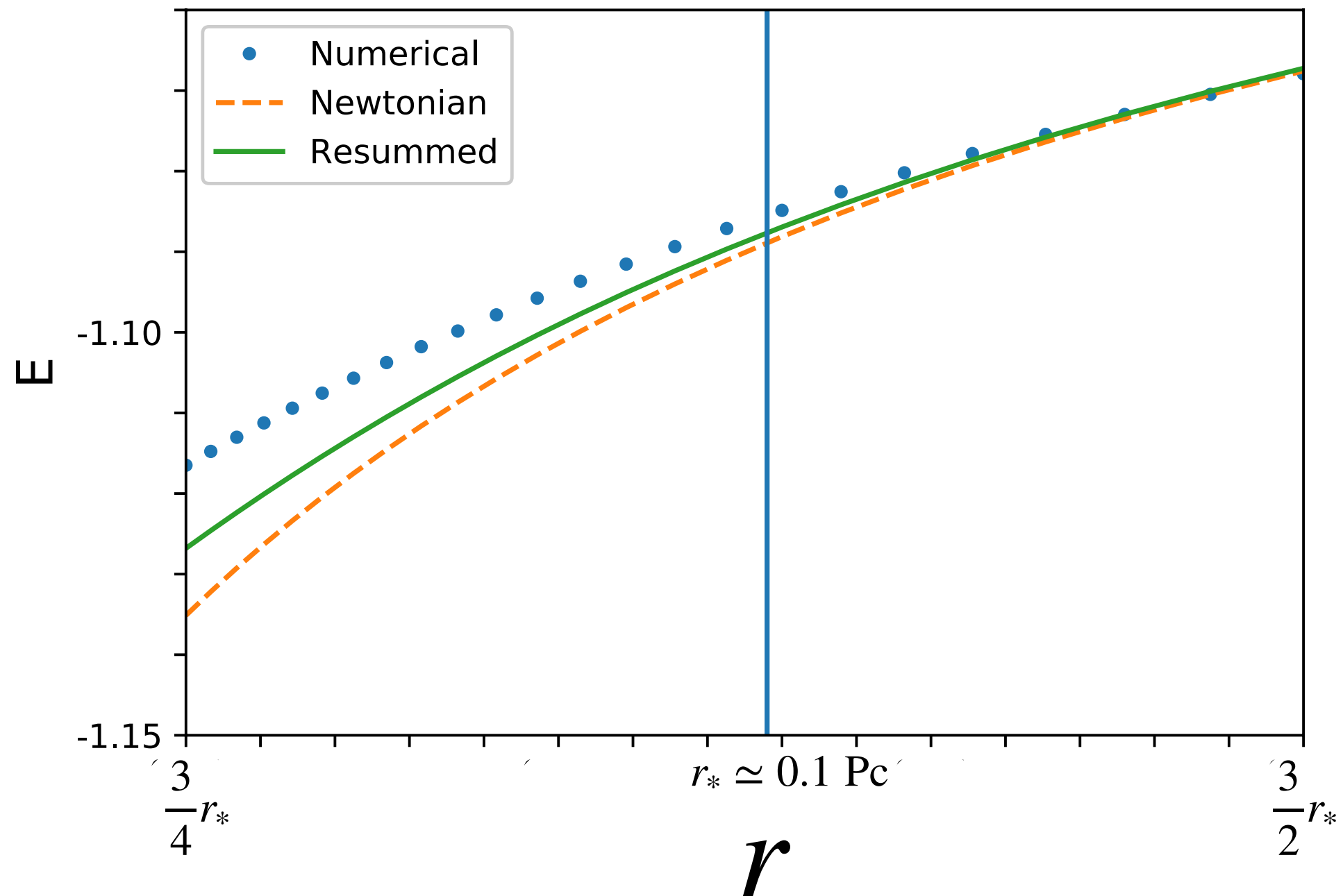

Effective One-Body (EOB) : outside

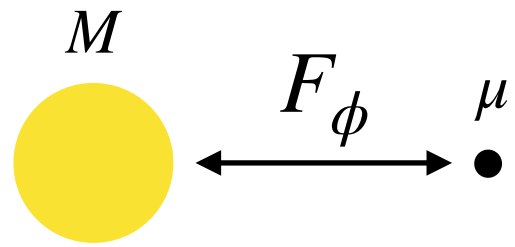

$$E_{\text{tm}} = \mu\phi(r) = \mu \left(-\frac{M}{r} + \frac{M^3}{5r^5} + \dots \right)$$

Effective One-Body (EOB) : outside

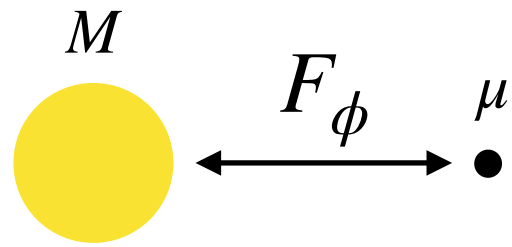

$$E_{\text{tm}} = \mu\phi(r) = \mu \left(-\frac{M}{r} + \frac{M^3}{5r^5} + \dots \right)$$

$$E_N = -\mu \frac{M}{r}$$

$$\frac{E_{\text{tm}}}{E_N} - 1 = -\frac{M^2}{5r^4} + \dots \ll 1$$

Effective One-Body (EOB) : outside

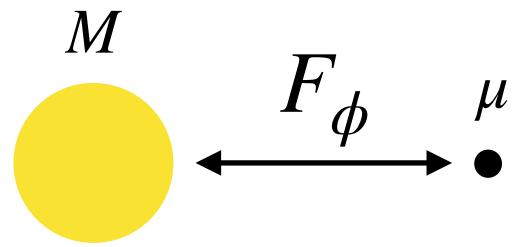

$$E_{\text{tm}} = \mu\phi(r) = \mu \left(-\frac{M}{r} + \frac{M^3}{5r^5} + \dots \right)$$

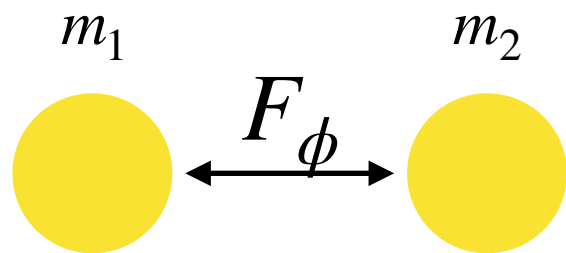

$$E = -\frac{m_1 m_2}{r} + \frac{m_1 m_2 (m_1^2 + m_2^2)}{5r^5} + \dots$$

Effective One-Body (EOB) : outside

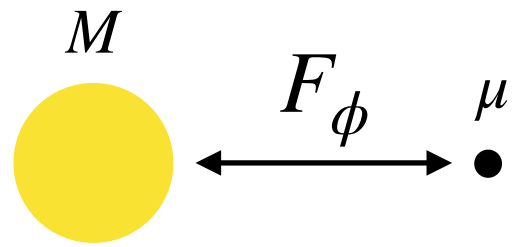

$$E_{\text{tm}} = \mu \phi(r) = \mu \left(-\frac{M}{r} + \frac{M^3}{5r^5} + \dots \right)$$

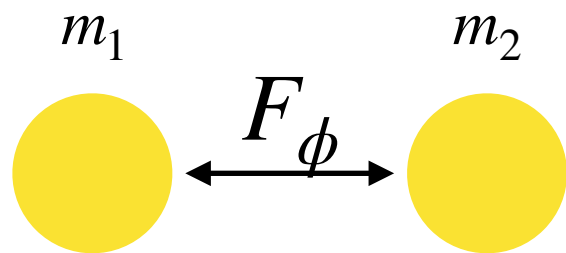

$$E = -\frac{m_1 m_2}{r} + \frac{m_1 m_2 (m_1^2 + m_2^2)}{5r^5} + \dots$$

$$\mu = \frac{m_1 m_2}{m_1 + m_2}$$

$$M = m_1 + m_2$$

$$x = \frac{m_1}{m_1 + m_2}$$

$$= \mu \left(-\frac{M}{r} + \frac{M^3}{5r^5} (x^2 + (1-x)^2) + \dots \right)$$

The two-body energy is a deformation of the test-mass energy

Energy map outside

Idea : resum nonlinearities by using only E_{tm}

$$E_{tm} = \mu \left(-\frac{M}{r} + \frac{M^3}{5r^5} + \dots \right) \quad E = \mu \left(-\frac{M}{r} + \frac{M^3}{5r^5} (x^2 + (1-x)^2) + \dots \right)$$

Energy map outside

Idea : resum nonlinearities by using only E_{tm}

$$E_{tm} = \mu \left(-\frac{M}{r} + \frac{M^3}{5r^5} + \dots \right) \quad E = \mu \left(-\frac{M}{r} + \frac{M^3}{5r^5} (x^2 + (1-x)^2) + \dots \right)$$

$$\frac{E}{E_{tm}} = 1 + \frac{M^2}{5r^4} (1 - x^2 - (1-x)^2) + \dots$$

$$\frac{E}{E_{tm}} = a_0 + a_1 \left(\frac{E_{tm}}{E_N} - 1 \right) + a_2 \left(\frac{E_{tm}}{E_N} - 1 \right)^2 + \dots$$

Inside the nonlinear radius

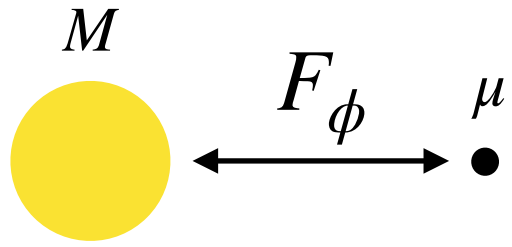

$$E_{\text{tm}} = 3\mu (Mr)^{1/3} + \dots$$

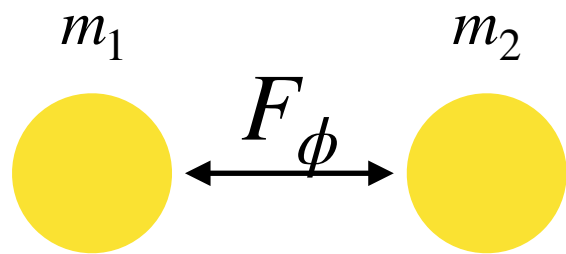

?

Inside the nonlinear radius

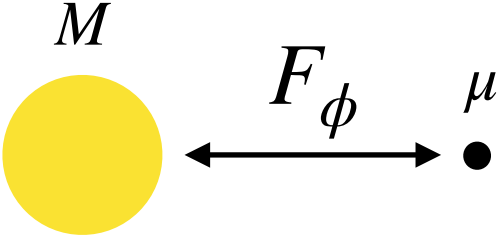

$$E_{\text{tm}} = 3\mu (Mr)^{1/3} + \dots$$

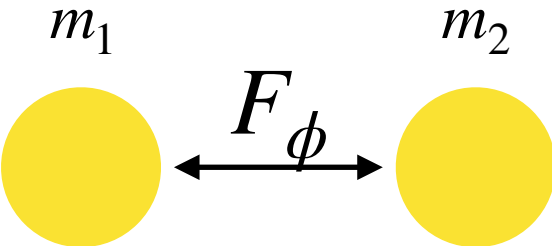

?

$$r < r_* \Leftrightarrow (\nabla\phi)^2 < (\nabla\phi)^4$$

$S_{\text{cl}} =$

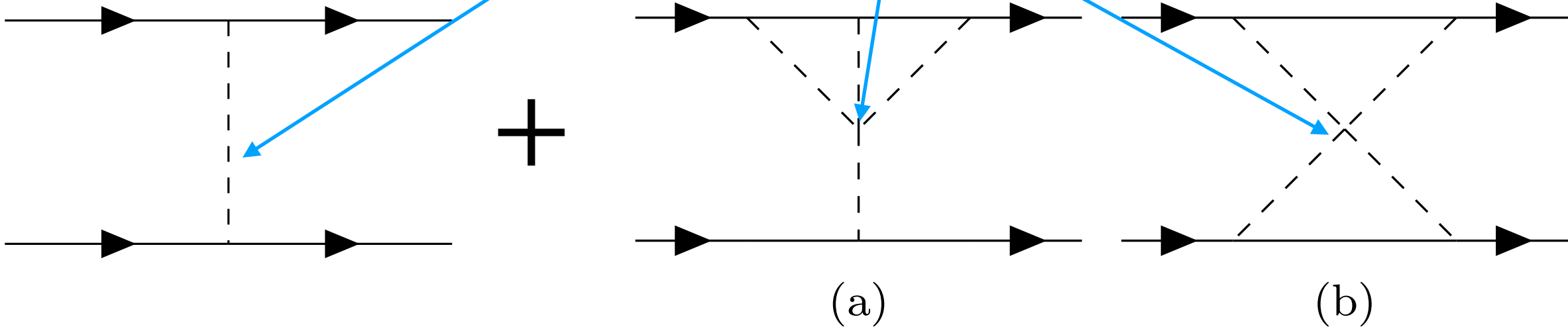

+ ... **Diverges**

Inside the nonlinear radius

Idea: Postulate that the energy map is valid inside

$$\frac{E}{E_{\text{tm}}} = b_0 + b_1 \left(\frac{E_{\text{tm}}}{E_{\text{ref}}} - 1 \right) + b_2 \left(\frac{E_{\text{tm}}}{E_{\text{ref}}} - 1 \right)^2 + \dots$$

One cannot compute the b_i 's, but one can get them with a numerical simulation !

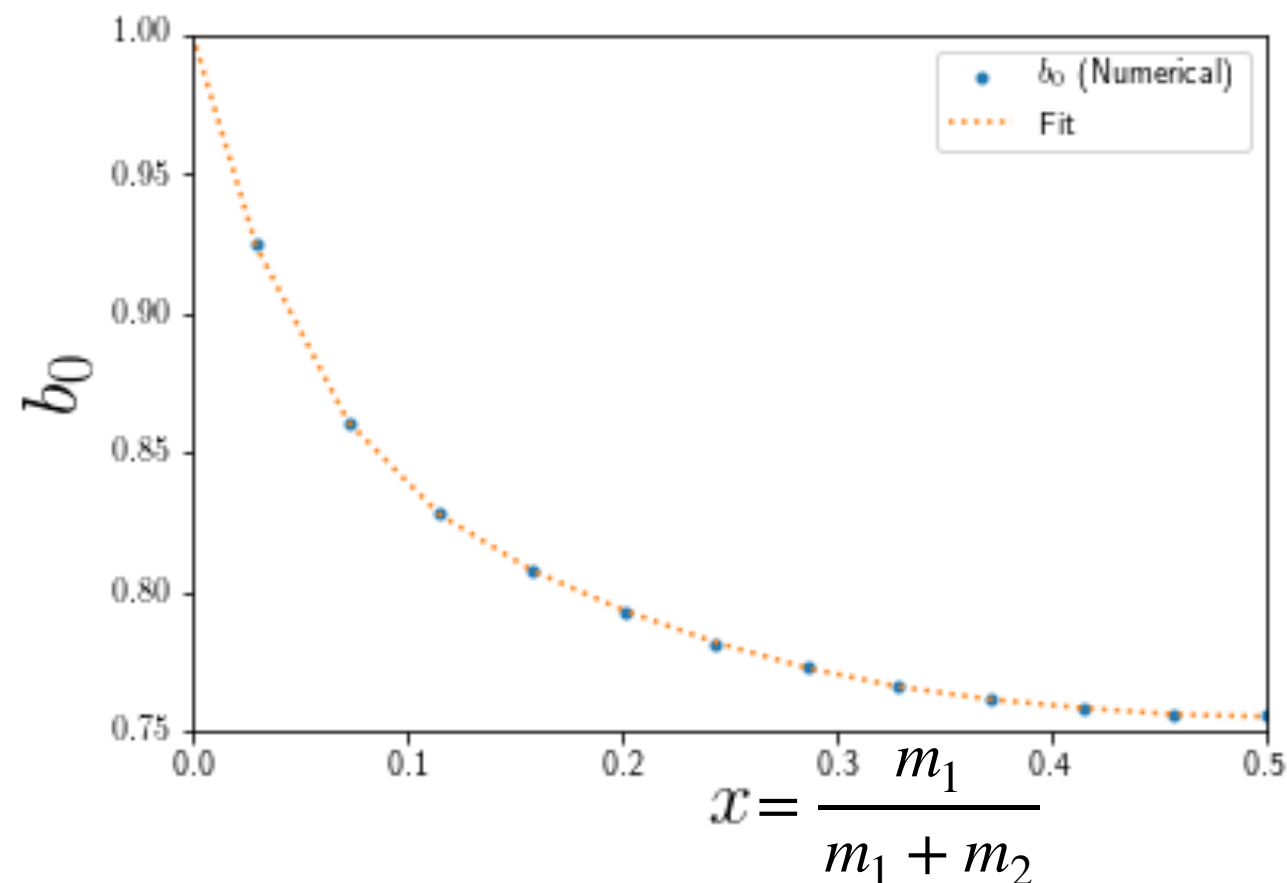

EP violation

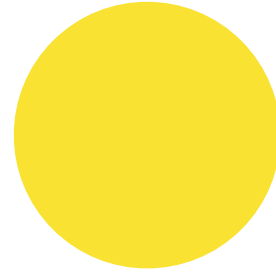
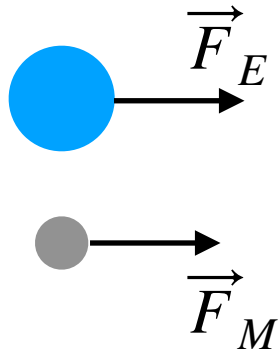

The Moon is a test-mass :

$$\vec{F}_M = -\vec{\nabla} E_M \simeq -m_M \vec{\nabla} \phi_S(r)$$

and

$$\vec{F}_M = m_M \vec{a}_M$$

$\Rightarrow \vec{a}_M = \vec{\nabla} \phi_S(r)$ does not depend
on m_M

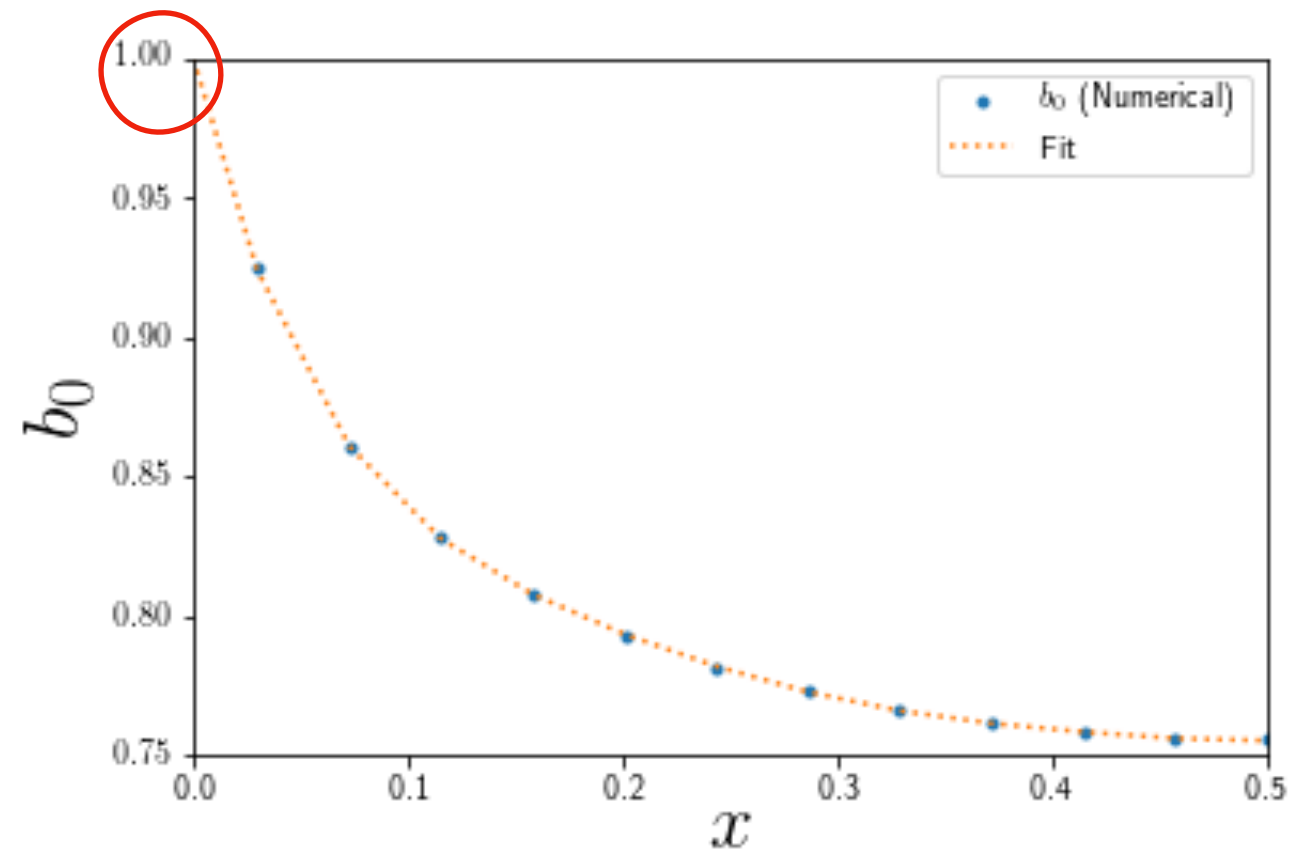

EP violation

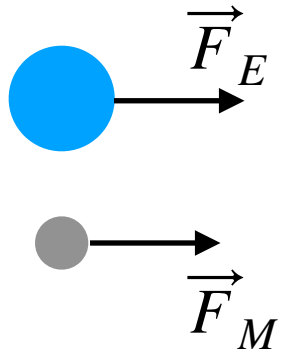

The Earth is **not** a test-mass :

$$\vec{F}_E \simeq -m_E b_0(x_{SE}) \vec{\nabla} \phi_S(r)$$

and

$$\vec{F}_E = m_E \vec{a}_E$$

$\Rightarrow \vec{a}_E = b_0(x_{SE}) \vec{\nabla} \phi_S(r)$ **depends on x_{SE} !!**

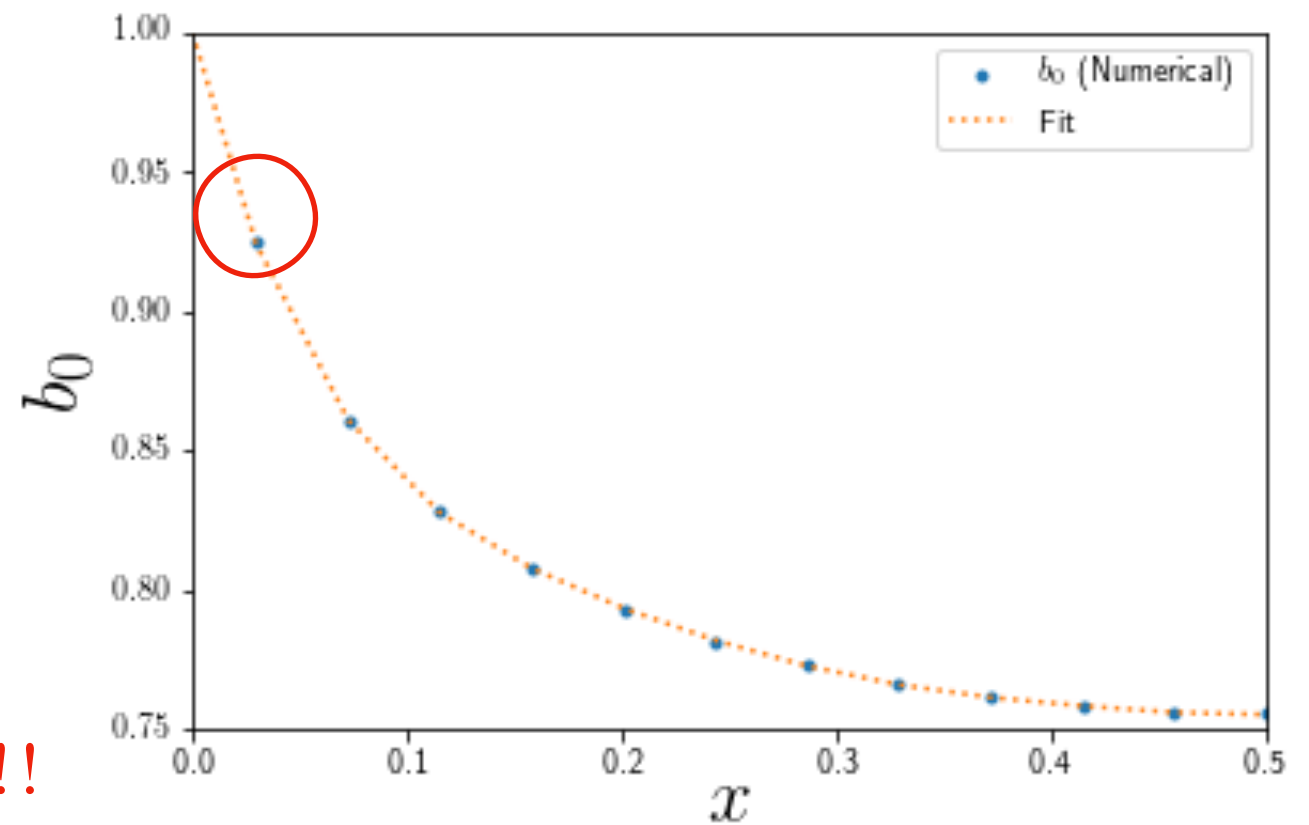

The Sun-Earth-Moon system

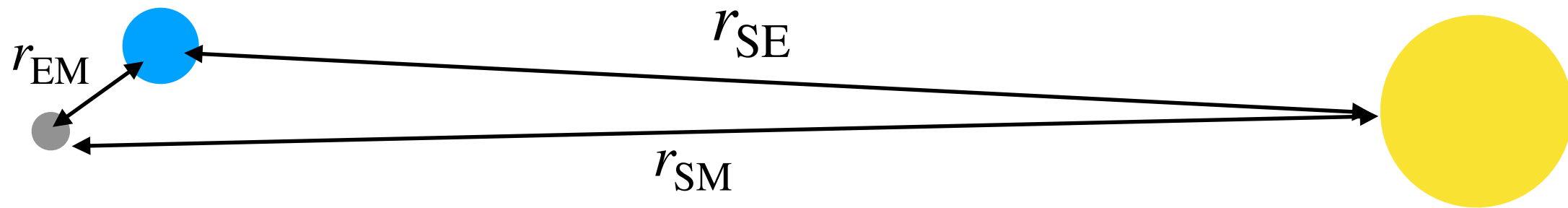

$$L_{\text{int}} = \frac{Gm_S m_E}{r_{SE}} \left(1 + b_0(x_{SE}) \left(\frac{r_{SE}}{r_*} \right)^n \right) + \frac{Gm_S m_M}{r_{SM}} \left(1 + b_0(x_{SM}) \left(\frac{r_{SM}}{r_*} \right)^n \right) + \frac{Gm_E m_M}{r_{EM}} \left(1 + b_0(x_{EM}) \left(\frac{r_{EM}}{r_*} \right)^n \right)$$

K-Mouflage : $n = 4/3$
 $r_* = \sqrt{M}$

Galileon-3 : $n = 3/2$
 $r_* = M^{1/3}$

The Sun-Earth-Moon system

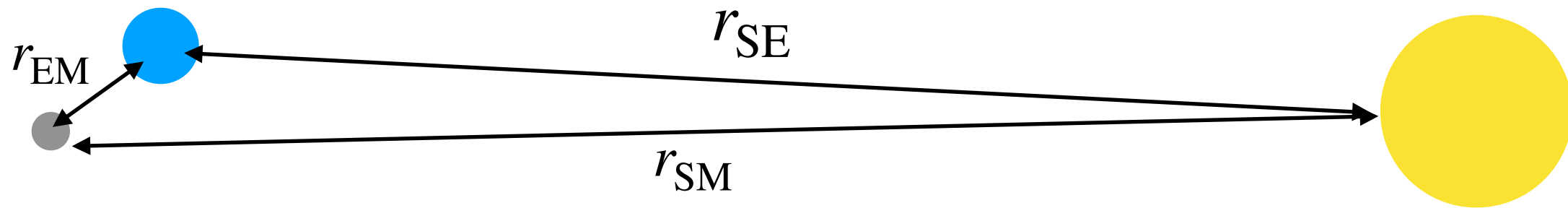

Needs to verify

$$\frac{r_{EM}}{r_{*,E}} \ll \frac{r_{SE}}{r_{*,S}}$$

$$L_{\text{int}} = \frac{Gm_S m_E}{r_{SE}} \left(1 + b_0(x_{SE}) \left(\frac{r_{SE}}{r_*} \right)^n \right)$$

$$+ \frac{Gm_S m_M}{r_{SM}} \left(1 + b_0(x_{SM}) \left(\frac{r_{SM}}{r_*} \right)^n \right)$$

$$+ \frac{Gm_E m_M}{r_{EM}} \left(1 + b_0(x_{EM}) \left(\frac{r_{EM}}{r_*} \right)^n \right)$$

The Sun-Earth-Moon system

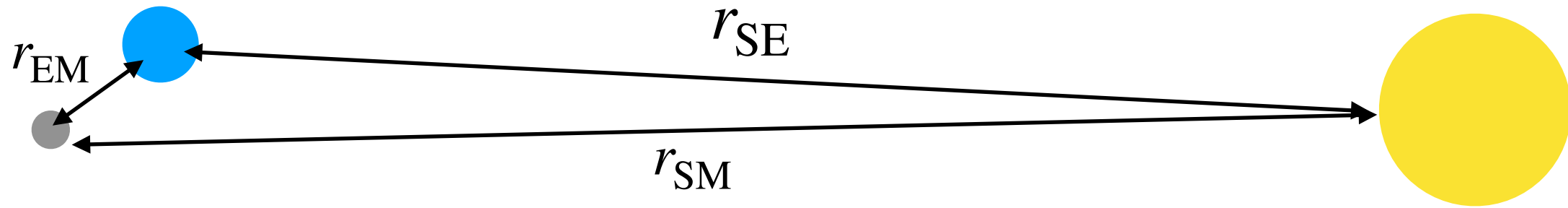

Needs to verify

$$\frac{r_{EM}}{r_{*,E}} \ll \frac{r_{SE}}{r_{*,S}}$$

$$L_{\text{int}} = \frac{Gm_S m_E}{r_{SE}} \left(1 + b_0(x_{SE}) \left(\frac{r_{SE}}{r_*} \right)^n \right) \leftarrow \text{Earth anomalous perihelion}$$

$$+ \frac{Gm_S m_M}{r_{SM}} \left(1 + b_0(x_{SM}) \left(\frac{r_{SM}}{r_*} \right)^n \right)$$

$$+ \frac{Gm_E m_M}{r_{EM}} \left(1 + b_0(x_{EM}) \left(\frac{r_{EM}}{r_*} \right)^n \right) \leftarrow \text{Moon anomalous perihelion}$$

The Sun-Earth-Moon system

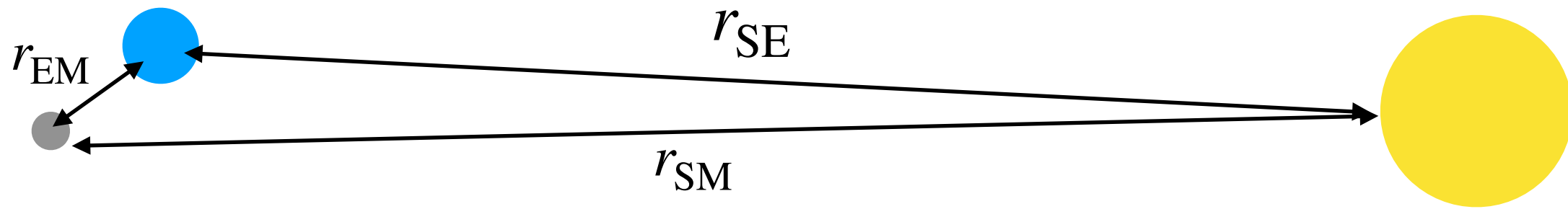

Needs to verify

$$\frac{r_{EM}}{r_{*,E}} \ll \frac{r_{SE}}{r_{*,S}}$$

$$L_{\text{int}} = \frac{Gm_S m_E}{r_{SE}} \left(1 + b_0(x_{SE}) \left(\frac{r_{SE}}{r_*} \right)^n \right) \leftarrow \text{Earth anomalous perihelion}$$

$$+ \frac{Gm_S m_M}{r_{SM}} \left(1 + b_0(x_{SM}) \left(\frac{r_{SM}}{r_*} \right)^n \right)$$

$$+ \frac{Gm_E m_M}{r_{EM}} \left(1 + b_0(x_{EM}) \left(\frac{r_{EM}}{r_*} \right)^n \right) \leftarrow \text{Moon anomalous perihelion}$$

Not relevant for EP violation

The Sun-Earth-Moon system

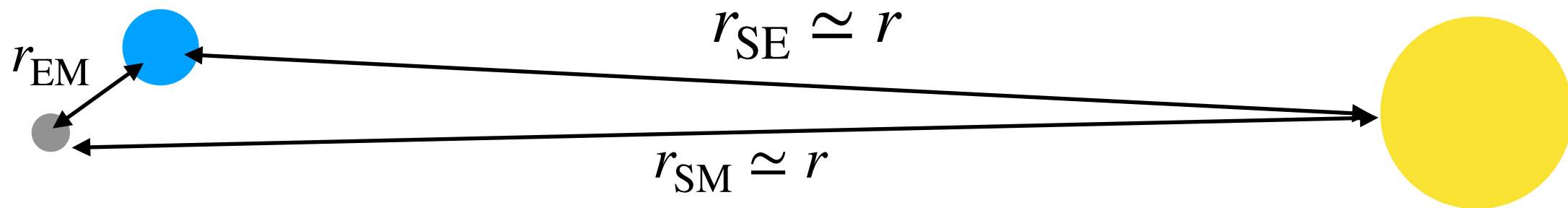

Expand L_{int} in the EM center-of-mass frame using $\frac{r_{EM}}{r} \ll 1$:

$$L_{\text{int}} = \frac{Gm_S(m_E + m_M)}{r} \left(1 + [(1 - x_{EM})b_0(x_{SE}) + x_{EM}b_0(x_{SM})] \left(\frac{r}{r_*} \right)^n \right) \\ + G\mu_{EM}m_S \frac{r_{EM}^i r_i}{r^3} \left((1 - n)(b_0(x_{SE}) - b_0(x_{SM})) \left(\frac{r}{r_*} \right)^n \right)$$

The Sun-Earth-Moon system

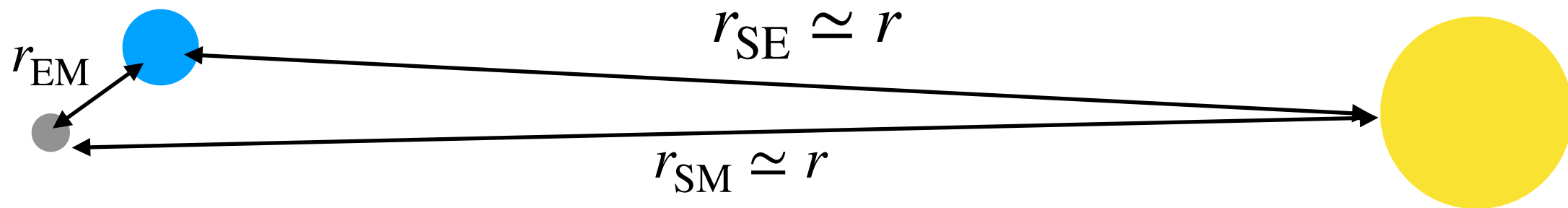

Expand L_{int} in the EM center-of-mass frame using $\frac{r_{EM}}{r} \ll 1$:

$$L_{\text{int}} = \frac{Gm_S(m_E + m_M)}{r} \left(1 + [(1 - x_{EM})b_0(x_{SE}) + x_{EM}b_0(x_{SM})] \left(\frac{r}{r_*}\right)^n \right) \\ + G\mu_{EM}m_S \frac{r_{EM}^i r_i}{r^3} \left((1 - n)(b_0(x_{SE}) - b_0(x_{SM})) \left(\frac{r}{r_*}\right)^n \right)$$

'GM' of Earth-Moon modified : very hard to observe

EP violation

The Sun-Earth-Moon system

Let's focus on the EP violating term :

$$L_{\text{int}} = G\mu_{EM}m_S \frac{r_{EM}^i r_i}{r^3} \left((1-n)(b_0(x_{SE}) - b_0(x_{SM})) \left(\frac{r}{r_*} \right)^n \right)$$
$$\simeq G\mu_{EM}m_{\odot} \frac{r_{EM}^i r_i}{r^3} \left((1-n)\alpha_1 x_{SE} \left(\frac{r}{r_*} \right)^n \right)$$

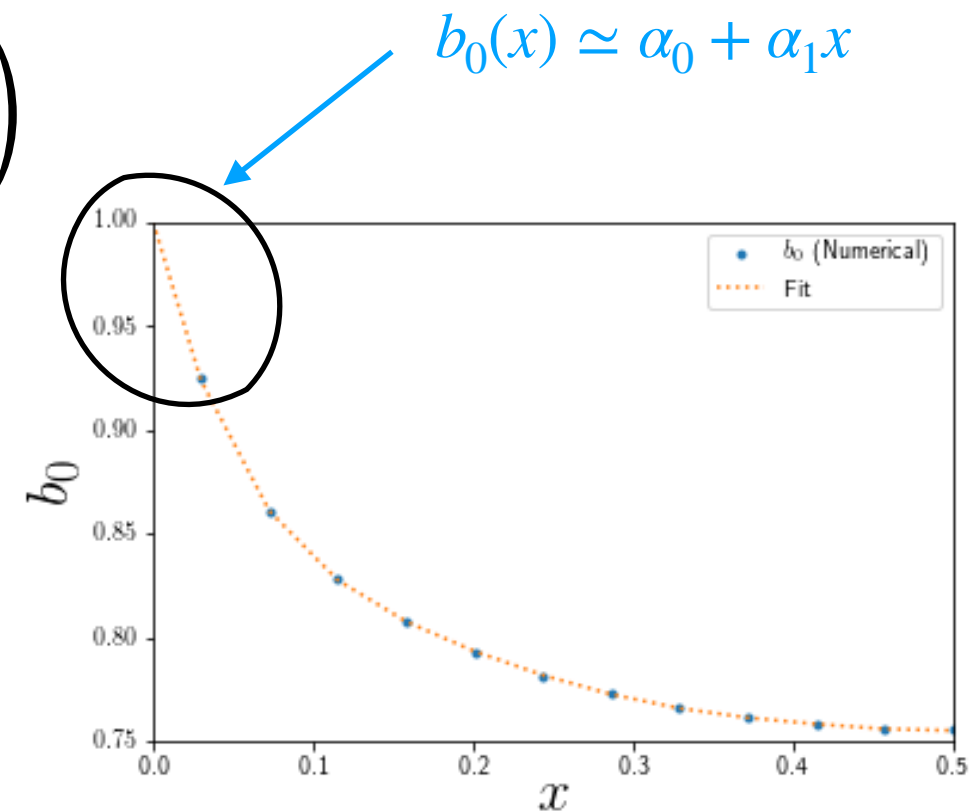

The Sun-Earth-Moon system

Let's focus on the EP violating term :

$$L_{\text{int}} = G\mu_{EM}m_S \frac{r_{EM}^i r_i}{r^3} \left((1-n)(b_0(x_{SE}) - b_0(x_{SM})) \left(\frac{r}{r_*} \right)^n \right)$$

$$\simeq G\mu_{EM}m_{\odot} \frac{r_{EM}^i r_i}{r^3} \left((1-n)\alpha_1 x_{SE} \left(\frac{r}{r_*} \right)^n \right) \quad \leftarrow b_0(x) \simeq \alpha_0 + \alpha_1 x$$

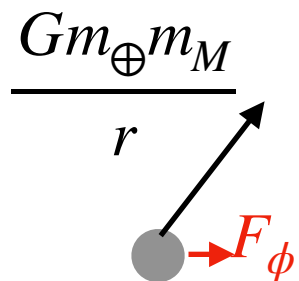

To the sun



$$\delta r_{EM} \simeq 3 \times 10^{12} \left| (1-n)\alpha_1 x_{SE} \left(\frac{r}{r_*} \right)^n \right| \text{ cm}$$

The Sun-Earth-Moon system

$$\delta r_{EM} \simeq 3 \times 10^{12} \left| (1 - n) \alpha_1 x_{SE} \left(\frac{r}{r_*} \right)^n \right| \text{ cm}$$

This gives a constraint :

$$\alpha_1 x_{SE} \left(\frac{r}{r_*} \right)^n \lesssim 10^{-13}$$

Since $x_{SE} \simeq 10^{-6}$, **the perihelion constraint is better :**

$$\alpha_0 \left(\frac{r}{r_*} \right)^n \lesssim 10^{-11}$$

Conclusions

- The two-body problem triggers lots of developments in analytic GR. They can be transposed to modified gravity.
- Future directions : conservative and dissipative dynamics of inspiralling compact objects with screening ; GW from hairy black holes (analytic results in the extreme mass-ratio case)